

PAPER • OPEN ACCESS

IoT-based Fire Detection and Prevention System

To cite this article: . Ch Hariveena *et al* 2020 *IOP Conf. Ser.: Mater. Sci. Eng.* **981** 042080

View the [article online](#) for updates and enhancements.

You may also like

- [Influence of logging on the effects of wildfire in Siberia](#)
E A Kukavskaya, L V Buryak, G A Ivanova et al.
- [Sentinel-1 observation frequency significantly increases burnt area detectability in tropical SE Asia](#)
Joao M B Carreiras, Shaun Quegan, Kevin Tansey et al.
- [Modeling the effects of fire severity and climate warming on active layer thickness and soil carbon storage of black spruce forests across the landscape in interior Alaska](#)
H Genet, A D McGuire, K Barrett et al.



The Electrochemical Society
Advancing solid state & electrochemical science & technology

242nd ECS Meeting

Oct 9 – 13, 2022 • Atlanta, GA, US

Early hotel & registration pricing
ends September 12

Presenting more than 2,400
technical abstracts in 50 symposia

The meeting for industry & researchers in

BATTERIES
ENERGY TECHNOLOGY
SENSORS AND MORE!



ECS Plenary Lecture featuring
M. Stanley Whittingham,
Binghamton University
Nobel Laureate –
2019 Nobel Prize in Chemistry



IoT-based Fire Detection and Prevention System

Hariveena. Ch¹, K. Anitha² and Potharaju Ramesh³

^{1,3}Department of ECE, CMR Engineering College, Hyderabad, India

cherukuhariveena@gmail.com rameshvlsi87@gmail.com

²Department of ECE, St. Martin's Engineering College, Secunderabad, India

anithaece@smec.ac.in

Abstract. Fire identification in homes is important to prevent property loss due to both natural and triggered fire events. Fire identification will prove to be very critical since the difference between life and death may mean it. Fires will come from anywhere and at any moment, but the existence of a fire alarm device helps to keep the family safe. The need to get a fire alarm device isn't seen by certain people. They just think they're going to smell the fire and sprint out of time. The typical time for a building to burn down is just 60 seconds today. So the fire has probably consumed the house by the time you smell the fire and decide to run inside. The Internet of Things (IoT) is a collection of wired and internet-accessible computers. In the IOT, the 'Stuff' may apply to any physical unit, ranging from a toaster to a vehicle. Over the Internet, these machines can be linked and help us manipulate or gather data from them. We will be using a wide range of sensors in this paper to sense the presence of fire and alert the watchman and fire officials to its presence. In addition, a preventive solution is often introduced by putting a sprinkler on it that sprinkles the water when the fire is sensed by smoke sensors.

Keywords— Raspberry Pi, Internet of Things, Smoke sensor, Sprinkler and Dc motor

1. Introduction

Fire is very lethal, resulting in the destruction of human life and property. Fire detection systems are important to mitigate the loss of personal items caused by both man-made and induced fire. The National Crime Statistics Bureau reports that during the years 2010 to 2014, there were a total of 113961 deaths related to fire injuries. Every day, fire injuries claim approximately 65 casualties. Around 2010 and 2014, there were a total of 1.21 LAKH fire injuries. Thankfully, the number of fire injuries has been gradually decreased with the use of more intelligent fire warning devices. One of the most dangerous characteristics of fire is that it grows rapidly and will propagate uncontrollably with the right medium. To prevent a fire threat, timely identification of fire is therefore necessary. The Internet of Things is a series of sensors, actuators, apps, home appliance-embedded electronics, physical devices and vehicles that attach to each other to attach and share data, helping to improve the performance of ordinary equipment using computer-based systems. It not only aims to increase a device's performance, but it also has economic benefits. By designing smart gadgets, IoT is yet another way to make daily life better for humans. In the year 2017, IoT devices rose by 31 percent and hit 8.4 billion. By the year 2020, the cumulative amount is set to hit 30 billion devices. The market size of IoT products is also projected to grow to 7.1 million dollars by 2020. IoT includes linking items that are used for everyday uses outside the range of normal computers. We also created an IoT-based fire alarm with additional methods of protection and verification in this article. In order to detect the



precise location of the origin of the flames, systems use a broad range of sensors-PIR sensors. The gas sensor senses the presence of some CO₂-like flammable gas. The temperature sensor senses any unexpected changes in the temperature of the room. Using a Raspberry Pi 3, the networking and data compilation is completed. When a suspicious behaviour is observed by the sensors, the web camera attached to the unit takes a snapshot of the environment and sends it to the watchman and the nearest fire stations. The watchman has a 120-second grace period to validate the fire and its authenticity. The fire marshals appear at the scene to put out the fire upon its authentication. The unit sends a red warning to the fire station demanding their immediate arrival if the message is unanswered by the watchman for 120 seconds. The idea of this research is to develop a network by dispersed wireless sensors that are randomly scattered throughout the forest and to establish a stable self-organized network between the sensors to protect all the large areas in the forests that can be used. The role of the sensor network is to detect fire every 10-15 minutes in the coverage area between time intervals and send a alert signal to the main server. All sensors in the vicinity area will be active when the fire is identified and order to stop the routine activity [1]. The sensors are fitted with a limited wireless communication range. Until the signal hits the drain, the data will be transferred from one sensor to another. When the sink receives the data, from the calculation rate of the fire spreads, it will begin to do routine processing to verify if the fire specifically reflects the danger zone. If the processing outcome is consistent, so the sink decides the location of the burn. First, the sink sends an warning signal to the fire department which gives information about the precise location of the fire which reports the temperature and velocity of the fire[2, 3] , In order to arrive at an optimal conclusion, the fire brigade will be able to determine the complexity and nature of the situation and take estimated steps before the fire becomes uncontrollable. The forest fire kills not just the forest wealth (trees) but also the flora and fauna of the whole area, severely disrupting biodiversity. There is no rain during the summer season, the woodland is riddled with dried senescent leaves and twigs that might explode into flames.

2. Proposed System

In a destructive way, flames inflict significant damage and interrupt everyday life. Preventing them or reducing their repercussions is also a high priority. While there are several systems that have been developed to solve this issue, false alarms are an obstacle that is yet to be avoided. The location to be tracked is under continuous observation by a closed-circuit television in our model. Several sensors are mounted at tactical locations. An ultrasonic sensor, a temperature sensor, a heat sensor and a gas sensor are used in the sensor. In detecting a fire if it happens, each sensor plays a critical role. The primary benefit of this method is that its precision is very high. If the fire has been identified, the protection and the closest fire service will be given a mail.

2.1. Working

The flame sensor detects the flame 's existence and in a database stores the meaning. To assess the presence of smoke, the smoke sensors sense the particles found in the air. The output value is stored in the database again. The gas sensor detects that there is the presence of inflammable gases / liquids that could have triggered the fire. All the data obtained from the sensors and the web camera is stored in a database. This data is then separated to deduce the detection accuracy. The email is sent to the base security and the fire department when the precision is above the agreed threshold. The fire department starts the rescue operation after approval from the protection.



Figure 1.Raspberry pi

3. Experimental Description

3.1. Raspberry Pi

It is an ultra-cheap minicomputer with 5.5 cm width and 9 cm length. It consists of a component named System on Chip (SoC) which comprises of single core CPU with a supportive processor for computing floating points, GPU and RAM with 512 MB size (SD-RAM). Moreover, it consumes less power, which is just around 5-7 watts. The architecture of raspberry pi is given in figure 1. It has couple of cache memory levels, where first level is of 32KB size and the latter is of 128KB size. These are utilized to store recent programs and ALU is utilized to execute instructions.

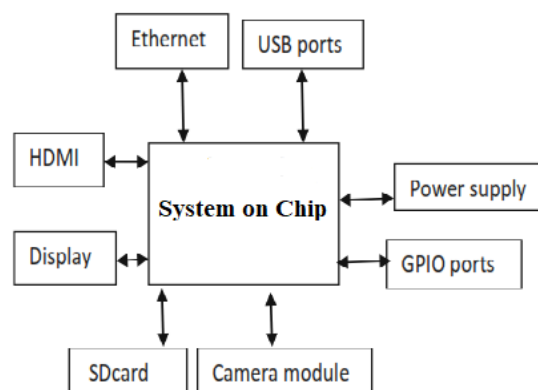

Figure 2.System architecture of raspberry pi

Table 1. Specifications of Raspberry pi

Chip	Broadcom BCM2835 SoC
Core architecture	ARM 11
CPU	700 MHz Low power ARM1176JZFS
RAM	512 MB (SD-RAM)
OS	Linux
Dimensions	85.6 × 53.98 × 17 mm
Power	Micro USB socket, 5 V, 1.2 A

It is a very small device and can incorporate other devices also. It consists of both the hardware and software. It requires an SD card and a power supply to related mouse and keyboard. Additionally, a display also exists for functioning OS such as Windows and Linux.

3.2. Gas sensor

As the name suggests, the gas sensor detects gas leaks or other pollutants that can be used to subtract what happened or will happen which is very useful, particularly in fire safety.

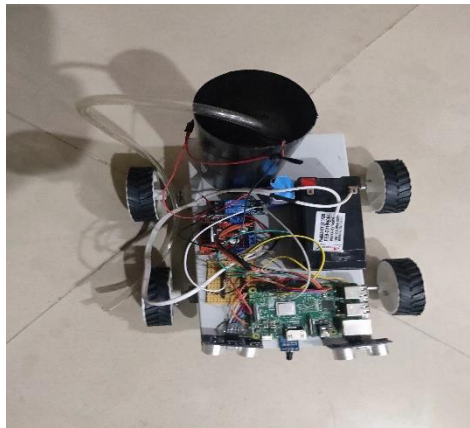

Figure 3. Fire detection and prevention robot

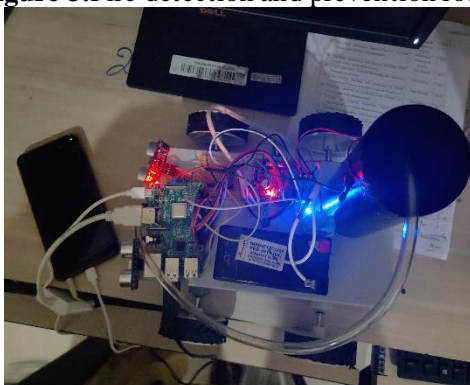

Figure 4. When fire detected by the smoke sensor then motor will be ON for sprinkling the water



Figure 5. Obstacle avoidance

4. Conclusion

The paper depicts the need for fire protection and an appropriate response. The key idea used was IoT and the project draws largely on the methods already existing and has solved several challenges in previous systems. But still, to have a more functional and functioning model, there are some tweaks and remodelling needed. For practical usage, the time required for the method should be minimised.

5. References

- [1] E. D.Breejen, et al., “Autonomous forest fire detection”, *In Proceedings of 3rd International Conference on Forest Fire Research and 14th Conference on Fire and Forest Meteorology*, Luso, Portugal, 16–20, 2003– 2012.
- [2] C. Hartung and R. Han, “Fire WxNet: A Multi Environments”, *4th International Conference of Mobile Systems, Applications and Services*, 2006.
- [3] DX. Viegas, “Fire Behaviour and Fire line Safety”, *Annual Mediterranean Burns Club*, vol. **6**, no. 3, 1993.
- [4] J. H. Scott, “Introduction to Wildfire Behaviour Modelling”, *National Interagency Fuels, Fire and Vegetation Technology, Wildland Fire Management RD&A*, 2012.
- [5] A. A. Alkhatib, “A Review on Forest Fire Detection Techniques”, *International Journal of Distributed Sensor Networks*, Article ID: 597368, 2014.
- [6] F. B. Vicente, N. Carbajal, L. Felipe, L. and P. Martínez, “Estimation of Total Yearly CO2 Emissions by Wildfires in Mexico during the Period 1999-2010”, *Advances in Meteorology*, 2014, Article ID: 958457, 2014.
- [7] Y. Zhao, Z. Zhou, and M. Xu, “Forest Fire Smoke Video Detection Using Spatiotemporal and Dynamic Texture Features”, *Journal of Electrical and Computer Engineering*, 2015, Article ID: 706187, 2015.
- [8] Vijayabaskar V. and Rajendran V. “Analysis and modeling of wind dependence of ambient noise in shallow water of Arabian sea”, *European Journal of Scientific Research*, Vol.**50**, pp.28-34(SJR IF: 0.21), Nov.2010.
- [9] Manjula P., Balachandra P. “An Analysis on Pricing Strategies of Software ‘I-Med’ in Healthcare Industry,” In: Mishra D., Nayak M., Joshi A. (eds) *Information and Communication Technology for Sustainable Development. Lecture Notes in Networks and Systems*, vol **9**. Springer, Singapore. https://doi.org/10.1007/978-981-10-3932-4_25_1
- [10] Shahada SA, Hreiji SM, Atudu SI, Shamsudheen S. Multilayer Neural Network Based Fall Alert System Using IOT. *International Journal of MC Square Scientific Research*, **11**(4):1-5, 2019.